

SETUP MONTAJE



**LZF**

**I-CLUB**

I ASL LED  
I A LED

I A LED



I ASL LED

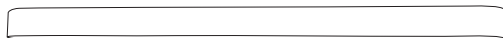

**I A LED**

- 1 x Shade Pantalla
- 4 x Screws & wall plugs Tornillos y tacos
- 1 x Level Nivel

**I ASL LED**

- 1 x Shade Pantalla
- 8 x Screws & wall plugs Tornillos y tacos
- 1 x Level Nivel



Additional Contents UL (Only for Junction Box)

- 1 x Adjustable Back Plate
- 2 x Screws & Spherical nuts
- 1 x Allen key N° 2,5



TECHNICAL SPECIFICATIONS ESPECIFICACIONES TÉCNICAS

**Integrated LED LED Integrado**

Class I Clase I



- IA:** Led module 500mA
- IASL:** Led module 900mA
- 120-277V: On/Off
- 120-277V: Dimmable 0-10V & TRIAC
- 60W 50-60Hz



- IA:** Led module 500mA
- IASL:** Led module 900mA
- 120-277V: On/Off
- 120-277V: Dimmable 0-10V & TRIAC
- 60W 50-60Hz

ON



OFF

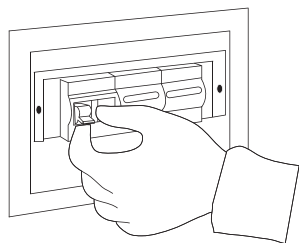

## 1 MARK THE WALL MARCAR LA PARED

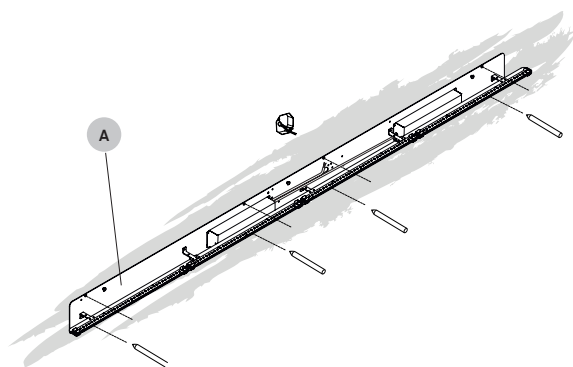

## 2 FIX TO THE WALL FIJAR A LA PARED

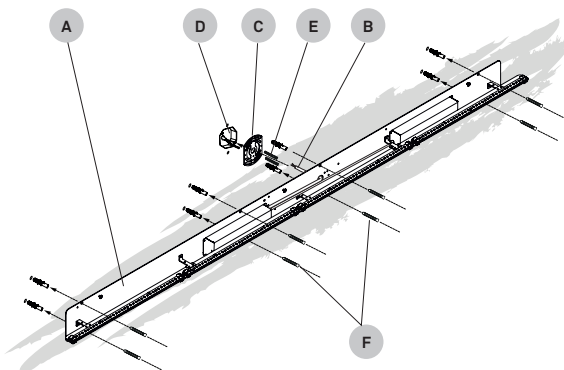

**IMPORTANT:** Turn off the power before installing your lamp.

**IMPORTANTE:** Desconectar la red eléctrica antes de instalar la luminaria.

**For US & Canada: skip steps 4 - 6.**

**For Europe: skip steps 1 - 3**

**Para EEUU & Canadá: sáltese los pasos de 4 a 6.**  
**Para Europa: sáltese los pasos de 1 a 3.**

Level the backplate (A) so its completely horizontal. Mark through the holes in the wall backplate (A) to drill the holes for wall plugs.

Make sure the junction box is completely covered by the backplate (A).

- Feed the electrical wires from the lamp through the adjustable Jbox cover plate (C) and then fix it to the junctionbox (D).
- Connect the electrical wires (B) to the mains as shown below.
- Use the screws & spherical nuts (E) to attach the fixture to the adjustable Jbox cover plate. Then, use the screws supplied (F) to attach the back plate to the wall.

**3** MAKING YOUR CONNECTION CONEXIÓN ELÉCTRICA

**NON DIMMABLE or BLUETOOTH or TRIAC**

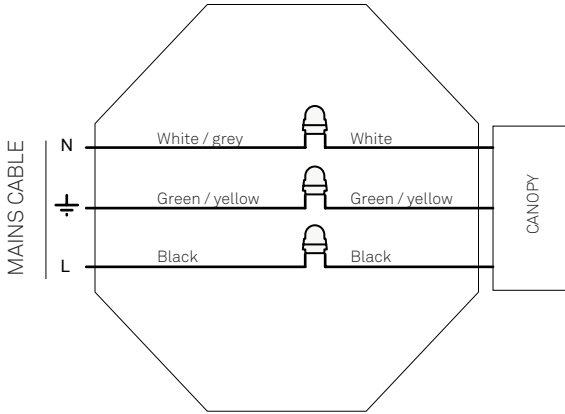

**ELECTRICAL CONNECTION OPTIONS**

**OPTION 1:**

NON DIMMABLE or BLUETOOTH or TRIAC  
 You will have three wires coming from the ceiling, inside de Junction Box (2).

Connect the Neutral (N), Ground (GND) and Line (F) to the corresponding cables coming from the canopy using connectors.

**DIMMING 0-10 V or DALI**

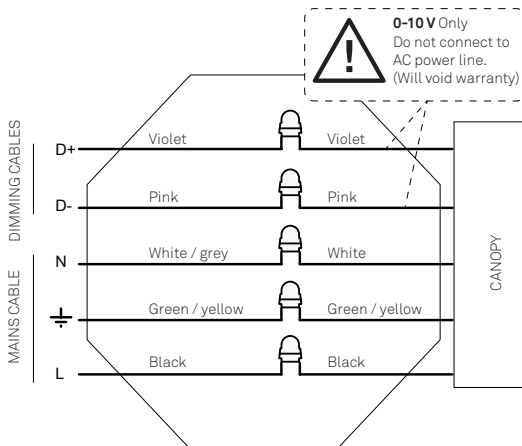

**OPTION 2: DIMMING 0-10V or DALI**

You will have five wires coming from the ceiling inside de Junction Box (2): power and dimming control.

Connect the Neutral (N), Ground (GND) and Line (F) to the corresponding cables coming from the canopy using connectors.

Connect the two dimming control wires +/- coming from the canopy using connectors.

**4** MARK THE WALL MARCA LA PARED

Level the backplate (A) so its completely horizontal. Mark through the holes in the wall backplate (A) to drill the holes for wall plugs.

Nivele la placa de trasera (A) para que quede completamente horizontal.  
 Marque los agujeros en esta placa trasera (A) para perforar los agujeros para los tacos.

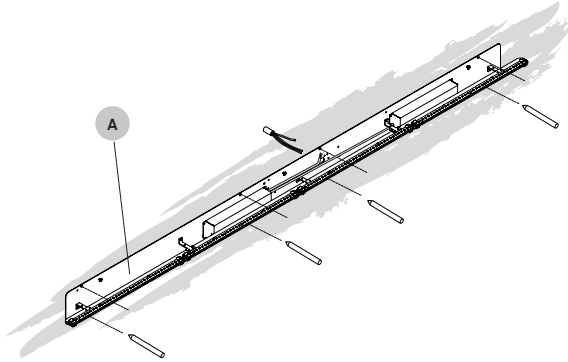
**5** FIX TO THE WALL FIJAR A LA PARED

Feed the electrical wires (B) through the back plate (A) fix it to the wall/ceiling with the screws (F) and connect the electrical wires to the main as show below.

Pasar los cables electricos (B) a través de la tapa trasera (A), fijar a la pared/techo con los tornillos (F) y preparar para conectar como se muestra a continuación.

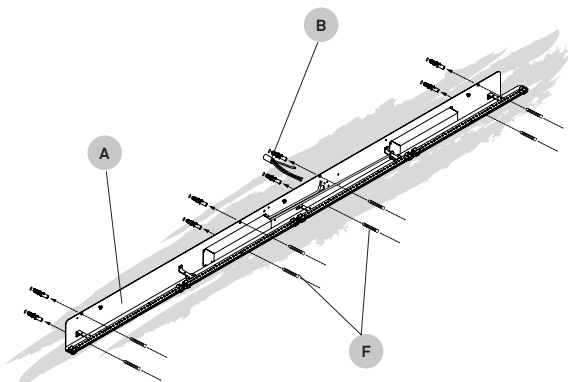

**6** MAKING YOUR CONNECTION CONEXIÓN ELÉCTRICA

**NON DIMMABLE or BLUETOOTH  
NO REGULABLE o BLUETOOTH**

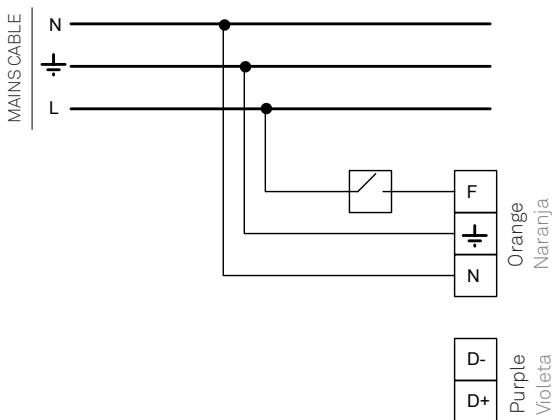

**ELECTRICAL CONNECTION OPTIONS**

**OPTION 1:**

NON DIMMABLE or BLUETOOTH

You will have three wires coming from the ceiling. Connect the Neutral (N), Ground (GND) and Line (F) to the corresponding connectors on the mains terminal block marked in orange.

**OPCIÓN 1:**

NO REGULABLE o BLUETOOTH

Tiene una manguera de tres polos que sale del techo. Conecte el neutro (N), tierra (GND) y la línea (F) en la posición correspondiente a cada uno en la regleta de conexión naranja.

**DIMMING 0-10V or DALI DIMMING 0-10V o DALI**

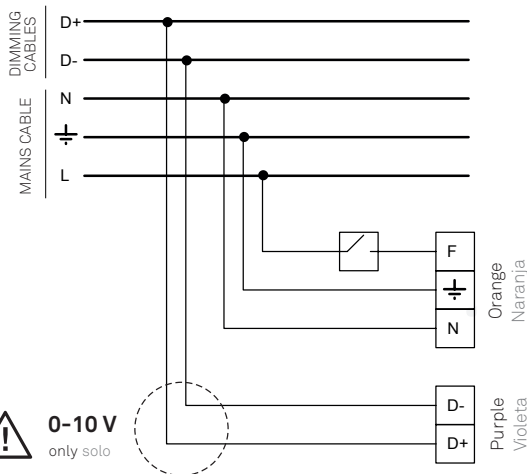

**!** 0-10V  
only solo

Do not connect to AC power line.  
Will void warranty.  
No conectar a la línea de corriente CA.  
Se anulará la garantía.

**OPTION 2: DIMMING 0-10V or DALI**

You will have five wires coming from the ceiling. Power and dimming control.

Connect the Neutral (N), Ground (GND) and Line (F) to the corresponding connectors on the mains terminal block marked in orange.

Take the two dimming control wires +/- and connect them to the dimming terminal block marked in purple.

NOTE: it is important to connect these according to the polarity marked on the dimming terminal block

**OPCIÓN 2: REGULABLE 0-10V o DALI**

Debería tener cinco cables que salen del techo. Conecte el neutro (N), tierra (GND) y la línea (F) en la posición correspondiente a cada uno en la regleta de conexión naranja.

Tome los dos cables restantes de regulación +/- y conéctelos a la regleta de conexión violeta.

NOTA: es importante conectarlos de acuerdo con la polaridad indicada en la regleta de regulación.

**7** PLACE SHADE COLOCAR PANTALLA

Put the shade back on the back plate through the fixing bolts (G). Then, to fix the lamp, move the shade to the right as show in the details below.

Coloque la pantalla en el soporte del aplique usando los tornillos de fijación (G). A continuación, para fijar la lámpara, mueva la pantalla hacia la derecha como se muestra en los detalles inferiores.

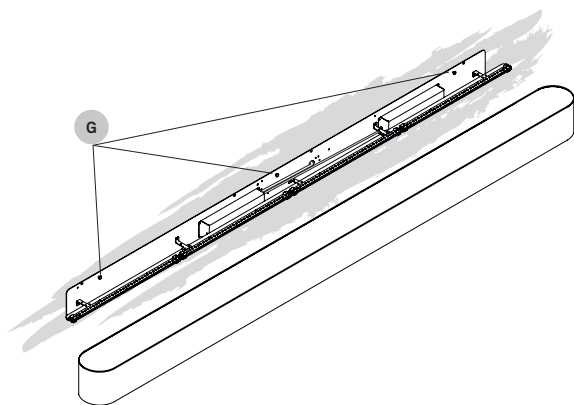

**8** FIX SHADE FIJAR LA PANTALLA

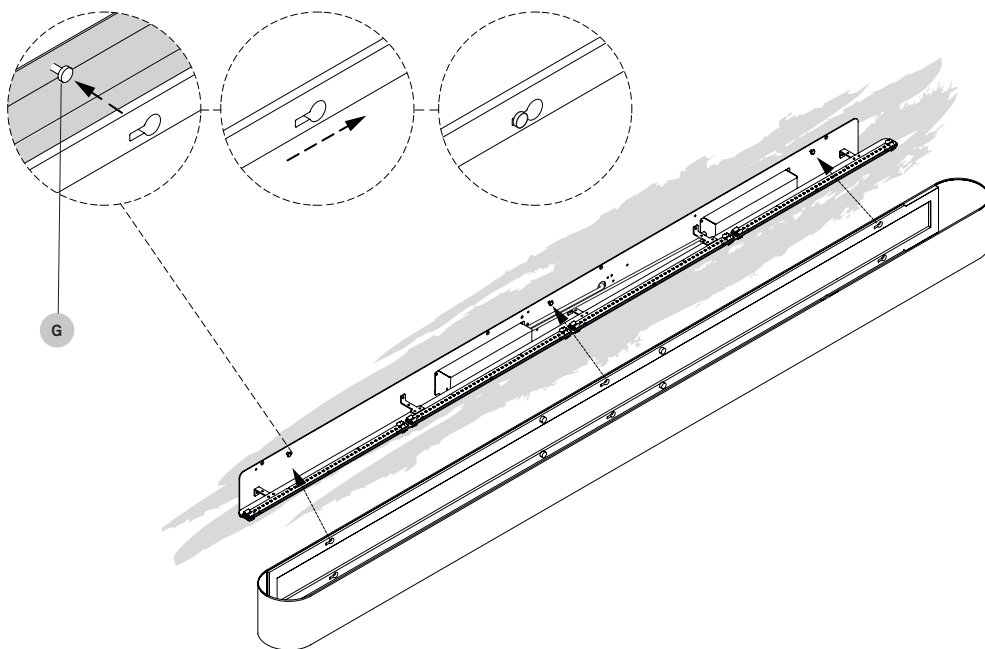

**Use and care of your lamp.**

You have just purchased an original handmade product by LZF. LZF is FSC® certified, dedicated to promoting responsible forest management worldwide. Our registered trademark license code is FSC® C110841. Your lamp is made from natural wood veneer from well-managed FSC® certified forests and other controlled sources, treated with our patented Timberlite® finish. This treatment both protects and safeguards the wood veneer against breakages...

**CLEANING OF ...**

The shades we recommend a feather duster or a damp cloth, clean only the flat surface of the veneer with the cloth, and please avoid any moisture contact along the edge of the veneer.

The metallic surfaces should be treated with care and cleaned with a soft damp cloth only. Make sure that moisture does not penetrate joins or junctions between metal parts. Use water. Do not use solvents or cleaning products any kind.

The acrylic diffusers on your lamp can be cleaned with a regular window cleaning spray and a soft cloth. Do not use solvents of any kind.

**PRECAUTIONS****Luminaire for indoor use only.**

Unplug the lamp before cleaning. Servicing or manipulation of the electrical installation should only be performed by qualified electrical personnel or by the LZF service department.

**Glass**

Improper handling can cause loosening or chipping of the glass. Any bubbles, or lack of homogeneity in the glass is a characteristic feature of hand blown glass and not a defect. The surface of the glass may also include imperfections due to its manual manufacturing.

When cleaning, use a window cleaning spray and a soft cloth.

Avoid handling glass without gloves to prevent fingerprints and loss of gloss.

**Wood veneer**

Avoid direct sunlight, strong indirect sunlight and moisture on your lamp. Since wood is a natural material, a gradual change in tone may occur over time. Furthermore, if the lamps were purchased at different times, there will be differences in colour and tone, particularly in lighter coloured veneers. This is can not be considered a manufacturing defect or reason for complaint. Do not install your lamp near any air-conditioning vents or ventilation shafts as this may damage the wood veneer used in this fixture.

**LEDS**

If your lamps contains Integrated LED circuits do not touch the LED surface with your bare hands as this can reduce the life of your LED.

**BULBS**

Bulbs are normally not included, unless indicated. We recommend using energy-saving LED bulbs. Please refer to the instruction manual or visit our website [www.lzf-lamps.com](http://www.lzf-lamps.com) to make sure you are using the best bulb for your type of lamp.

**KELVINS**

Depending on the color of the wood veneer we recommend using different Kelvin light temperatures, for their optimum appearance: Blue 28, Turquoise 30 and Grey 29: 4000k

Ivory White 20, Natural Beech 22, and Natural Cherry 21: 3000 or 4000k.

Yellow 24, Orange 25, Red 26, Chocolate 31 & Pale Rose 33: 3000k.

Learn more about Kelvins.

**Uso y cuidado de su lámpara**

Acaba de adquirir un producto original y hecho a mano por LZF. LZF cuenta con la certificación FSC®, dedicada a promover el manejo forestal responsable en todo el mundo. Nuestro código de licencia de marca registrada es FSC® C110841. Su lámpara está fabricada con chapa de madera natural proveniente de bosques certificados FSC® bien manejados y de otras fuentes controladas, tratada con nuestro acabado patentado Timberlite®. Este tratamiento protege la madera, a la vez que evita posibles roturas.

**LIMPIEZA DE ...**

La madera, recomendamos usar un plumero o un paño húmedo, evitando incidir en los cantos de la chapa.

Las superficies metálicas deben tratarse con cuidado y limpiarse únicamente con un paño suave y húmedo. Asegúrese de que la humedad no penetre en las uniones de las partes metálicas. Use agua. No use disolventes ni productos de limpieza de ningún tipo.

Los difusores acrílicos se pueden limpiar con un líquido limpia cristales y un paño suave. No usar disolventes de ningún tipo.

**PRECAUCIONES****Luminaria para uso exclusivo en interior.**

Desenchufar la lámpara antes de cambiar la bombilla o limpiarla. La manipulación de la instalación eléctrica debe efectuarse solo por personal cualificado o por LZF.

**Vidrio**

Un manejo inadecuado puede provocar que el vidrio se afloje o se astille. Cualquier burbuja, o falta de homogeneidad en el vidrio no es motivo de queja, este es un rasgo característico del vidrio soplado a mano.

La superficie del vidrio también puede presentar imperfecciones debido a su fabricación manual. Al limpiar, use un spray limpiacristales y un paño suave.

No manipule el vidrio sin guantes para evitar huellas dactilares y pérdida de brillo.

**Madera**

Evitar el sol directo o la luz indirecta del sol y la humedad sobre la lámpara. Debido a que la madera es un material natural, pueden existir variaciones en el tono de ésta. Si las lámparas se adquieren en diferentes periodos de tiempo, pueden mostrar variaciones de color y tono sobre todo en las maderas de tonos claros. No situar la lámpara próxima a un salida de aire debido a que éste puede ocasionar daños en la misma. Luziferlamps S.L. no se hará responsable.

**LEDS**

Si su lámpara contiene LED integrado. No tocar nunca con las manos desnudas, ya que esto puede reducir la vida útil de su LED.

**BOMBILLAS**

Las bombillas no están incluidas, a menos que se indique. Recomendamos utilizar bombillas de bajo consumo LED. Consulte el manual de instrucciones o visite nuestro sitio web [www.lzf-lamps.com](http://www.lzf-lamps.com) para asegurarse de que está utilizando la mejor bombilla para su tipo de lámpara.

**KELVINS**

Dependiendo del color de la chapa de madera recomendamos utilizar diferentes temperaturas de luz, para su óptimo aspecto:

Azul 28, Turquesa 30 y Gris 29: 4000k.

Ivory White 20, Natural Beech 22 y Natural Cherry 21: 3000 o 4000k.

Amarillo 24, Naranja 25, Rojo 26, Chocolate 31 y Rosa Palo 33: 3000k.



© Luziferlamps, S.L. All rights reserved. Valencia, Spain. 2020 - [www.lzf-lamps.com](http://www.lzf-lamps.com) - [support@lzf-lamps.com](mailto:support@lzf-lamps.com)